

DISPELLING THE BLACK MAGIC OF SOLDER PASTE

Tony Lentz

FCT Assembly
Greeley, CO, USA

ABSTRACT

Solder paste has long been viewed as “black magic”. This “black magic” can easily be dispelled through a solder paste evaluation. Unfortunately, solder paste evaluation can be a challenge for electronic assemblers. Interrupting the production schedule to perform an evaluation is usually the first hurdle. Choosing the solder paste properties to test is simple, but testing for these properties can be difficult. Special equipment or materials may be required depending upon the tests that are chosen. Once the testing is complete, how does one make the decision to choose a solder paste? Is the decision based on gut feel or hard data?

This paper presents a process for evaluating solder pastes using a variety of methods. These methods are quick to run and are challenging, revealing the strengths and weaknesses of solder pastes. Methods detailed in this paper include: print volume, stencil life, response to pause, open time, tack force over time, wetting, solder balling, graping, voiding, accelerated aging, and others. Hard data is gathered and used in the evaluation process. Also presented in this paper are a set of methods that do not require expensive equipment or materials but still generate useful data. The goal is to help the electronics assembler choose the best solder paste for their process.

Key words: solder paste evaluation, stencil life, response to pause, open time, tack force, wetting, solder ball, graping, voiding

INTRODUCTION

There are a wide variety of solder pastes available in the market that can be used for diverse applications. Each solder paste has strengths and weaknesses, and each solder paste is not ideal for every application. How do you know which solder paste is best for your process? The technology behind solder paste might be considered “black magic”. This does not have to be the case. It is the goal of this paper to present a process for evaluating solder pastes objectively and dispel the “black magic”. The evaluation process consists of many methods which highlight strengths and weaknesses of each solder paste. The reader can choose the methods to test the solder paste properties which are important to her or him. The amount of time required for an evaluation depends upon the methods chosen. A typical evaluation can take as little time as 30 minutes or as much as 8 hours. Also presented in this paper is a system of scoring solder paste performance. This scoring system can be customized so that the most important solder paste properties are weighted appropriately.

Several papers have been published which include methods for solder paste evaluation. Many of the methods used are based on industry standards. Some papers presented new methods for solder paste evaluation, but some of these methods used materials and equipment that might not be readily available. Most of these papers did not use a system of scoring solder paste performance. Judgment of overall solder paste performance was therefore subjective. A brief summary of these papers follows.

Lasky, Santos, and Bhav¹ discussed solder paste printability, tack, and reflow coalescence, with a focus on solder paste volumes and response to pause. The idea was to screen out solder pastes based on print performance before testing other properties. A 12-circuit board evaluator was presented. This method involved printing 4 circuit boards, followed by a pause of 1 hour, printing 4 more circuit boards, followed by another 1 hour pause, and then printing the final set of 4 boards. Solder paste volume and brick definition were the main metrics used for evaluation of solder paste performance.

Jensen² presented a selection of important criteria when making the transition from leaded to a lead free solder paste. The following ideas were discussed for initial screening of solder pastes: lot-to-lot consistency, reliability via Surface Insulation Resistance (SIR) and electrochemical migration, and supplier service and support. Several printing methods were detailed for secondary screening: stencil life, response to pause, and shear thinning. Reflow profiles for lead free solder pastes also were considered. Solder paste evaluation techniques were presented as a 4 step process. Step 1 set the print parameters. Step 2 challenged solder paste through variations in reflow profile to establish the reflow process window. Step 3 used the 12-board evaluator as presented by Lasky, Santos, and Bhav¹. Step 4 evaluated the resistance to shear thinning. These steps were intended to screen out solder pastes as each was completed.

Nguyen, Geiger, and Shangguan³ presented a process for solder paste evaluation including the use of a Flextronics test vehicle. The test vehicle included patterns for printability, slump, wetting, solder balling, voiding and SIR. Solder paste printability was tested initially and again after 4 hours. Print speeds were varied, and a range of area ratios (0.3 to 0.8) were used in a method of measuring missing deposits. IPC standard slump, solder balling and wetting tests were used. Solder pastes were screened out and the leaders were evaluated further. Reflow performance was evaluated using low, medium and high profiles in both air and nitrogen atmospheres. Solder pastes were rated for solder balls, wetting, voiding, and head in pillow defects. General observations were made about the data gathered.

Nguyen, Aranda, Geiger, and Kurwa⁴ evaluated low silver solder pastes, and a Flextronics multi-function test vehicle was used. Solder paste printability was tested initially and again after 4 hours. Print speeds were varied, and a range of area ratios (0.3 to 0.8) were used in a missing deposit method. IPC slump, solder balling and wetting tests were used. Reflow performance was evaluated using low, medium, and high profiles in an air atmosphere with Organic Solderability Preservative (OSP) surface finish. Voiding was evaluated for Ball Grid Array (BGA) and Quad Flat No Lead (QFN) components. General observations were made about the data gathered.

Guene, and Teh⁵ presented a set of methods to evaluate several key parameters of both no-clean and water-soluble solder pastes. Solder paste print performance was evaluated through several methods: viscosity, tack, slump, print speed, stencil life, and idle time. Viscosity was measured using two different types of viscometers. Tack force was evaluated over a 48 hour time period, and changes in tack were noted. Slump was evaluated using IPC standard methods. The solder paste was thermally stressed through storage at 40°C for 4 and 7 days. After thermal stress appearance, printability and tack force were evaluated. Viscosity over time was evaluated using a specific type of viscometer. Performance was compared using an Environment-Friendly Soldering Technology (EFSOT) verification board, which included areas for print definition and shorts (bridging). Maximum print speed and stencil life (idle time) was determined using this test board. Solder balling performance was determined using a hot plate with a variety of pre-heat cycles. Performance of the solder pastes was compared and contrasted with respect to the methods used. This is part one of a two part paper. The second part of the paper details a separate set of methods.

Xie, Baldwin, Houston, Lewis, and Wu⁶ evaluated no clean, lead free solder pastes for use with fine pitch 0402 and 0201 components. The following parameters were evaluated: stencil release capability, solder paste volume, wetting, flux residue cleaning, defects after component placement and reflow, and intermetallic layer formation and growth. A specific circuit board with Electroless Nickel Immersion Gold (ENIG) finish was used as a test vehicle. Initially a 10 print study was performed with a controlled sequence of underside cleaning. Solder paste average volume & standard deviation, and printed paste defects were used to screen out some solder pastes. Wetting was tested on clean and oxidized copper with a method similar to the IPC standard method. Flux residues were evaluated for ease of cleaning. Additional solder pastes were removed from testing due to poor performance. Defects after reflow and intermetallic growth from liquid to liquid thermal shock were used as final evaluation criteria. This study resulted in the choice of a solder paste for use in their process, which was different from the solder paste currently used.

Seelig, O'Neill, Pigeon, Maaleckian, Monson, Machado, and Shea⁷ presented a comparison of SAC305 vs. SN100C® solder pastes. Three different production circuit boards were used in this evaluation. Two profiles were used; one "cool" and one with standard temperatures. AOI was used to evaluate the appearance of the solder joints. Voiding and microstructural analysis was done. Component shear strength was measured before and after thermal aging. The SN100C® solder paste under evaluation was found to be a viable replacement for SAC305 solder paste.

Anson, McLaughlin, Argueta⁸ evaluated water-soluble and no-clean solder pastes for military and biomedical applications. A design of experiments (DoE) methodology was used in a holistic approach for this evaluation. Characteristics evaluated include solder balling, slump, printability, response to pause, voiding, wetting, cleanability, and ionic residue. Slump was measured using a range of humidity levels at time 0 and again after storage for 2 hours. Solder balling was tested using a modified IPC test method. Solder ball coupons were printed reflowed at time 0, stored at various humidity levels, and reflowed after 2 hours. A 10-print study with a pause between prints 5 and 6 was done using FR4 substrates. Bridging and insufficient solder deposits were measured. Reflowed solder joints were inspected for defects. Solder joints were cross sectioned in mixed alloy BGA arrays to ensure uniformity. Voids were measured in BGA arrays and on QFN thermal pads. Flux cleanability was evaluated using ionic contamination testing. Analysis of Variance (ANOVA) was used to compare the solder pastes within each method. Failure Mode Effects Analysis (FMEA) was used to weight and rank solder paste performance overall. An importance factor was assigned to each criterion and a score assessed for each solder paste within each criterion. The overall ranking for solder pastes was determined using the product of the importance factor and the score.

Stengel, Reichenberger, Ohm, Trodler, and Heilmann⁹ presented an overview of current industry wetting and spreading methods. Some methods apply only to solders or only to fluxes, while others apply to solder pastes. The methods discussed include slump, wetting balance, wetting angle, spread, and wetting area. The slump method involves printing a specified pattern of solder paste and storing the test substrates for a specified period of time at room temperature (cold slump) and elevated temperature (hot slump). The solder paste bricks and spaces are evaluated and a slump measurement is determined. Wetting balance is a method for evaluation of wetting force over time of a solder alloy, flux, or some combination of both. Temperature profiles can be varied in the wetting balance method. Wetting angle of the solder can be measured during the wetting balance test. Solder spread is typically measured by visual examination of spread area. Solder spread methods are typically used to evaluate fluxes and solid solders. Substrate preparation varies and can affect the results. Wetting area methods are similar to solder spread but are used for solder pastes. A new test method was introduced that uses specialized equipment to measure wetting force over time for solder pastes. This new method is similar in principal to the wetting balance method but is modified for use with solder pastes. Solder paste wetting is also determined through the use of test patterns that are intended to bridge during reflow. The amount of bridging that occurs is measureable and will vary based on surface finish and reflow profile used.

Guene and Teh¹⁰ presented a set of methods to evaluate several key parameters of both no-clean and water-soluble solder pastes. This is part two of a two part paper. Reflow performance was evaluated through several methods: wettability, reflow process window, graping, tombstoning, copper mirror and corrosion, SIR testing, and flux residue wash ability followed by ionic contamination testing. Wetting performance was evaluated using spread diameters on copper substrates. Preheat conditions and reflow profiles were varied. Wetting spread was quantified as a percentage of area. Graping was evaluated using the wetting patterns. Wetting performance was evaluated in a second method using a spread pattern on test circuit boards with ENIG and OSP finishes. The solder pastes were ranked in order of wetting performance. Tombstoning was evaluated through reflow of forty 0603 capacitors and calculation of a tombstoning percentage. Copper mirror, copper corrosion and SIR tests were performed using IPC standard methods. Cleanability of flux residues was evaluated in a cleaning machine using water at various temperatures and with the addition of cleaning agents. Ionic contamination testing was done after cleaning to quantify the results. Performance of the solder pastes was compared and contrasted with respect to the methods used.

Bruno and Johnson¹¹ presented a method for evaluating print performance and used that data to improve the print process. A novel test substrate was presented to be used for calibration of a solder paste inspection system. The parameters of the print process were varied and results were measured. Two different solder pastes were compared using printed volume measurements.

The process of evaluating a solder paste presented in this paper includes methods which evaluate important properties of the solder paste. These methods are practical, take little time, and are designed to be run by the solder paste user. This evaluation process generates hard data, which is used to compare the strengths and weaknesses of solder pastes. The overall performance of each solder paste is quantified using a scoring system.

TEST VEHICLE FOR EVALUATION

The process of evaluating solder paste starts with a good test design that uses readily available equipment and materials. Many properties of solder pastes can be evaluated through the use of test boards. The test boards shown below (Figures 1 - 6) were adopted from the Jabil solder paste evaluation kit. These circuit boards are readily available on the open market. These test boards were chosen so that the user would not have to design their own test board, or use a production board for the evaluation. Production circuit boards may not challenge solder pastes in all areas of interest.

Test circuit board F1

The F1 test circuit board (Figure 1) has three 0.5 mm pitch BGA arrays (U1, U2, U3) and three 0.4 mm pitch BGA arrays (U4, U5, U6) which are used for solder paste volume measurements. It also has two bridging test patterns used to measure bridging after print.

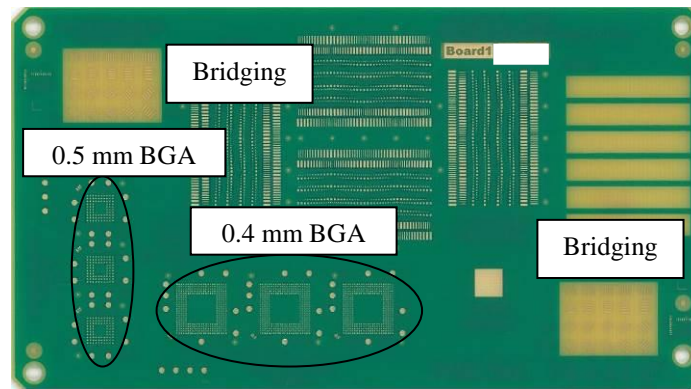
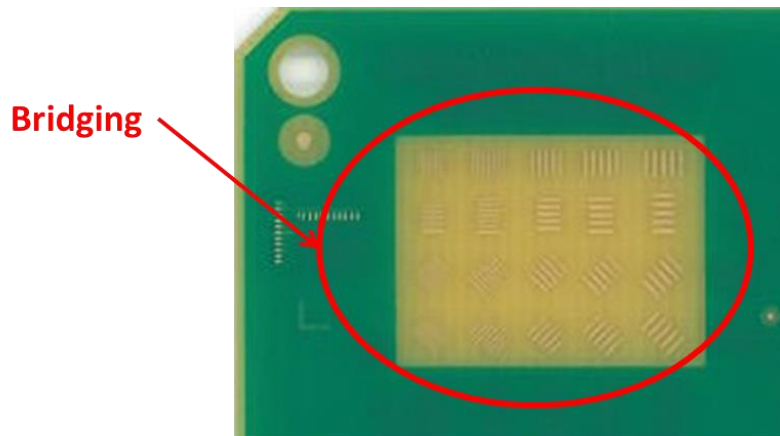

Figure 1 - F1 Test Circuit Board

When a 0.127 mm (0.005 inch) thick stencil is used, the 0.5 mm pitch BGA arrays have an area ratio of 0.575, and the 0.4 mm pitch BGA arrays have an area ratio of 0.500. These area ratios are small enough to challenge the printability of most solder pastes. There are a total of 252 pads in the 0.5 mm BGAs and 1080 pads in the 0.4 mm BGAs. A close up of one bridging pattern is shown below (Figure 2).



Pitch: 8, 12, 16, 18, 20 mils

Figure 2 - F1 Bridging Pattern

The pitch of the pads in the bridging pattern ranges from 8 to 20 mils. Both bridging patterns include a total of 208 opportunities for bridging. If the 8 mil pitch patterns are ignored, then the total number of bridging opportunities becomes 144 per circuit board.

Test circuit board F2A

The F2A test board (Figure 3) includes patterns to evaluate wetting, solder balling, voiding, and graping.

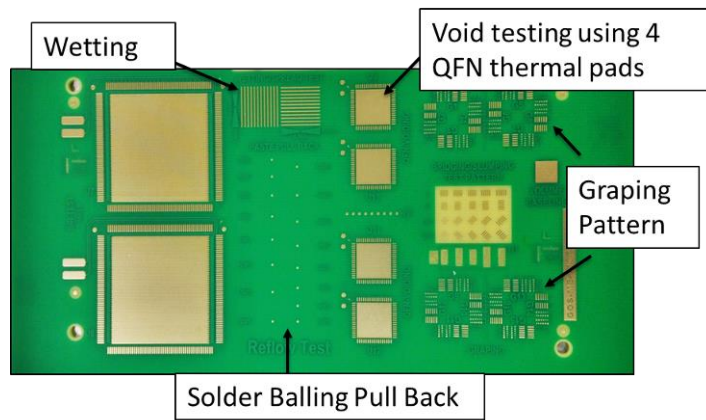

Figure 3 – F2A Test Circuit Board

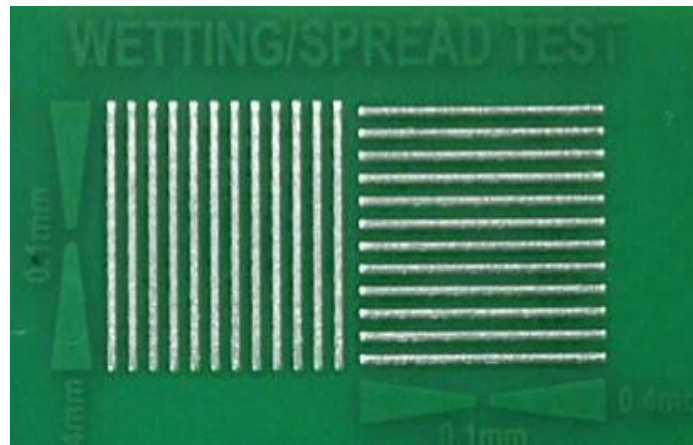

Figure 4 – F2A Wetting Pattern After Reflow

The wetting pattern (Figure 4) includes 12 vertical and 12 horizontal lines. Each line has 15 bricks of solder paste printed onto it for a total of 360 solder paste bricks. The pitch of the solder paste bricks ranges from 0.1 mm in the center of each line to 0.4 mm at the ends of each line. Typically an ENIG surface is used for wetting evaluation. If a more challenging wetting test is desired, then OSP surface finish can be used.

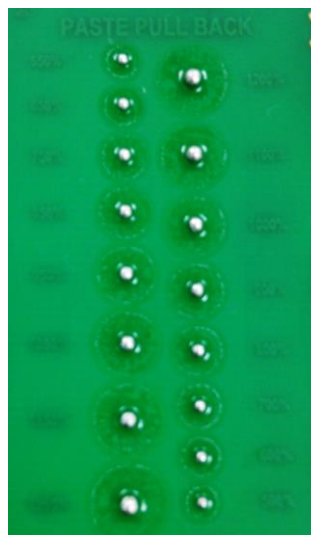

Figure 5 – F2A Solder Balling (Pull Back) Pattern After Reflow

The solder balling pattern (Figure 5) includes 16 overprinted pads of 20 mil diameter. The percentage area of overprint ranges from 500% to 1250%. The solder paste is overprinted onto the solder mask and the solder paste pulls back during reflow. The flux residue pools are inspected for solder balls.

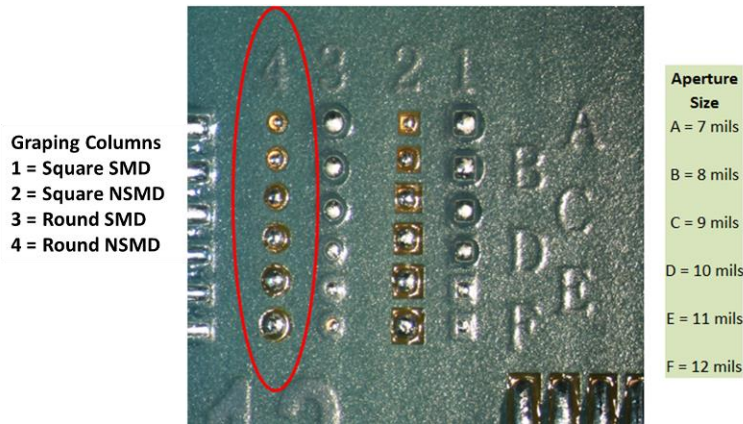

Figure 6 – F2A Graping Pattern After Reflow

The graping pattern (Figure 6) includes 4 columns of 6 pads each for a total of 24 pads. The columns include square and round pads, and both solder mask defined (SMD) and non-solder mask defined (NSMD) pads. The pad sizes range from 7 to 12 mils. The F2A test board includes 16 of these patterns, but a typical evaluation uses only 4 of them, for a total of 96 opportunities for graping.

Use of the F1 and F2A Jabil test boards is a good start for a solder paste evaluation. In some cases, this may be all that is required in order to compare and contrast solder pastes. Other properties can be easily tested using other methods. The methods for solder paste evaluation are detailed in the next section. Examples of test results are given along with each method. Variations on the methods are detailed, which may use different equipment or materials. The amount of time required for each method is estimated so the user can plan accordingly.

METHODS USED IN SOLDER PASTE EVALUATION

It is strongly recommended that each solder paste under evaluation be tested along with a control. The control solder paste should be one that the user is familiar with, and ideally is the solder paste used in the standard process. The results for two or more solder pastes should be compared and contrasted. This gives the user a baseline from which to judge performance of other solder pastes.

Solder paste volume average and standard deviation

It is generally accepted that a majority of defects in the surface mount assembly process occur at solder paste print. The goal of the solder paste print process is to put the correct amount of solder paste in the correct location on the circuit board and to do this with good repeatability. Solder paste average volume and standard deviation can be measured using the F1 test board in combination with a solder paste inspection system capable of measuring volume. Alternately, copper clad FR4 material can be used along with the F1 test stencil. This alternative minimizes errors due to alignment of stencil to pads, and due to variations in circuit board pad size or planarity.

This method consists of a 10 print study and the volume of solder paste in the 0.5 mm and 0.4 mm BGA arrays is measured. Printing is done with no underside cleaning of the stencil between prints. Solder paste bridging can be measured concurrently with this method. The number of prints could be reduced from 10 to 4 if time occupying the printer is a concern. 10 prints are desirable in order to get a more statistically significant number of data points. Average and standard deviation of volume are calculated separately for the 0.5 mm and 0.4 mm pitch BGAs. Example results are shown below (Table 1).

Table 1 – Example Results for Solder Paste Volume

Solder Paste	0.5 mm BGA Volume Avg. (mil ³)	0.5 mm BGA Volume Std. Deviation (mil ³)	0.4 mm BGA Volume Avg. (mil ³)	0.4 mm BGA Volume Std. Deviation (mil ³)
A	610	35	450	25
B	570	50	420	40

In this example, solder paste A gave higher average volumes and lower standard deviations for both sizes of BGA arrays. Higher solder paste average volumes are desirable as an indicator that the solder paste will give adequate volume for tighter pitch components. Lower standard deviations of volume are desirable and indicate better print repeatability. Solder paste A performed better than solder paste B in this test.

This method should be run using standard print parameters, and the same parameters should be used for each solder paste tested. If a more challenging test of printability is desired, then the print speed can be varied. Each solder paste can be run at normal print speed, and then again at a faster speed. For example, if the standard print speed is 25 mm/sec and the printer is occasionally run at 50 mm/sec, then both speeds should be tested with each solder paste. Higher print speeds typically result in lower volumes and higher standard deviations. Some solder pastes may not perform well at higher print speeds.

The estimated time for this method is approximately 5 minutes per print plus setup and cleanup. The total time for a 10 print study is approximately 60 minutes. A 4 print study can be run in approximately 30 minutes.

Alternate method for solder paste volume average and standard deviation

What if you do not have a 3D solder paste inspection system? This method measures the amount of solder paste printed by mass, using an electronic balance rather than a solder paste inspection system. Electronic scales are more economical than a Solder Paste Inspection (SPI) system and are readily available from a multitude of sources.

This method uses a 10 print study, and the mass of the solder paste is determined using a balance accurate to the nearest 0.01 grams. Each circuit board must be numbered, weighed initially and weighed again after print. Solder paste mass is determined, and then average and standard deviations of mass are calculated.

This alternative method has a couple of advantages over the SPI method. It does not require a 3D SPI system, and F1 test boards and stencil do not need to be used. Any circuit board and stencil pattern can be used. A disadvantage of this alternative method is that it is not selective for component or aperture design and size. It is limited to giving an overall total amount of solder paste. The total mass of solder paste printed can still be used to compare and contrast different solder pastes. Example results are shown below (Table 2).

Table 2 – Example Results for Solder Paste Mass

Solder Paste	Average Mass (grams)	Std. Deviation of Mass (grams)
A	0.22	0.02
B	0.18	0.05

In this example, solder paste A gave higher average mass and lower standard deviation than solder paste B. Again, solder paste A performed better than solder paste B.

The estimated time for this method is approximately 2 minutes per print plus setup and cleanup. The total time for a 10 print study is approximately 30 minutes.

Solder paste bridging

Bridging after print can easily be measured using the F1 test board in conjunction with the solder paste volume method. It is simple to calculate a bridging percentage, which can be used to compare paste performance.

This method consists of a 10 print study using the F1 test board. The same circuit boards that were printed in the volume study are used for this method. Two bridging areas on each board are inspected and the total number of bridged gaps are counted (Figure 7). The total possible number of bridges per circuit board is 144 when the 8 mil pitch pattern is ignored. A bridging percentage is calculated out of 1440 possible for a 10 print study.

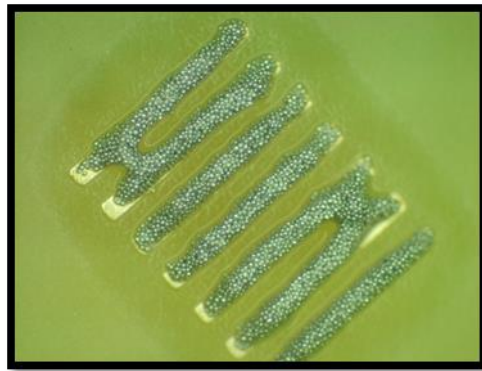

Figure 7 - Example of bridging after print

Example results: solder paste A gave 11.2 % bridging and solder paste B gave 8.9% bridging.

Lower bridging is desirable in order to prevent shorting. In this case, solder paste B performed better than solder paste A. Solder paste A gave higher volume in the solder paste volume method, which might contribute to higher bridging. There could be a trade off between solder paste volume and bridging. Higher bridging may be the result of higher solder paste volume. It should be noted that this method is intended to create bridging due to the lack of underside cleaning during 10 consecutive prints. In a standard print process, underside cleaning is used to help eliminate bridging.

Solder paste brick definition can be evaluated in conjunction with this method. Some solder pastes may give more crisp and clean looking bricks than others. The top of the bricks should be evaluated for scooping, peaks, and other non-conformities. This inspection results in a qualitative determination rather than a quantitative one, but it can help the user to gain a feel for differences in solder paste print performance.

The estimated time for this method is approximately 1 minute per circuit board, and this can be run concurrently with the volume measurement method. For example, bridging can be counted on the first board while solder paste volume is being measured on the second board. This method essentially adds no time to the volume method.

Reflow performance: Wetting, solder balling, graping, and voiding

Wetting, solder balling, graping, and voiding are measured simultaneously using the F2A test board. Components are only placed if voiding is going to be measured. The solder paste is reflowed and the data is summarized.

This method involves printing and reflowing two F2A circuit boards for each solder paste. A standard reflow profile should be used for all solder pastes tested. Microscopic inspection is used to evaluate wetting, solder balling, and graping. Voiding can also be measured. This requires placement of 4 dummy QFN components per board and then measurement of the voids using a X-ray system. The data is counted for both circuit boards of each solder paste and averaged.

The wetting or spread percentage is calculated by counting the number of solder paste bricks that join together out of a total of 360 possible per board. ENIG surface finish is typically used for this wetting test. A more challenging wetting test uses OSP surface finish. It is recommended to use the surface finishes commonly used in production, but the same surface finish should be used for all solder pastes evaluated. Solder balling is evaluated by looking for the largest overprint pattern that has 10 or less balls and the largest pattern with 5 or less balls. If the two boards differ in solder balling results, then an average overprint value is determined. Graping is determined by counting the total number of solder deposits showing graping in four of the graping patterns. The four patterns chosen should be in different locations on the circuit board, e.g. G1, G7, G10, and G15. Each graping pattern has 24 solder deposits, which results in a total possible graping of 96 when 4 patterns are used. Example results are shown below (Table 3).

Table 3 – Example Results for Wetting, Solder Balling, Graping, Voiding

Solder Paste	Wetting on ENIG (% spread)	Wetting on OSP (% spread)	Solder Balling Largest overprint 10 or less balls	Solder Balling Largest overprint 5 or less balls	Graping (%)	Voiding (Area %)
A	96	22	1250%	1200%	8.6	10.2
B	89	17	1100%	950%	20.4	9.5

Higher wetting values are desirable. This indicates good spread of the solder paste during reflow. In this case, solder paste A performed slightly better than solder paste B on the ENIG surface finish. Solder paste A also showed better wetting on OSP than solder paste B.

In the solder balling evaluation, higher overprint percentages indicate better performance. In this case, solder paste A showed less solder balling than solder paste B. Another way to evaluate solder balling is to look for the largest overprint pattern that has zero solder balls. This is a much more stringent evaluation that will result in lower overprint ratings for most solder pastes.

Low graping percentages indicate better performance. In this example, solder paste A performed better than solder paste B. Graping and solder balling typically show similar performance on the F2A circuit board. If there are many solder balls, and the overprint percentage ratings are low, then graping is usually high. Graping and solder balling can be caused by similar properties of the solder paste.

Low void area percentages are desirable. In this case solder paste B performed slightly better than solder paste A. It is not uncommon to see mixed results like this when using the F2A test circuit board. Solder paste A performed better than solder paste B for most of these parameters, except voiding. The user needs to decide which parameters are most important and rate solder paste performance accordingly.

Solder pastes might show different performance when tested with different reflow profiles. The user should decide the number and type of profiles to be tested with each solder paste. For example, if a linear ramp profile is used for most work, but a soak - ramp to peak type profile is used for certain types of circuit boards, then both should be tested. The solder paste under evaluation must perform with all of the commonly used profiles.

The estimated time for this method is approximately 30 minutes for each solder paste. If OSP is run in addition to the ENIG plated circuit boards, then the amount of time required will increase by about 20 minutes per solder paste.

Stencil life / Response to pause - F1 test board

Stencil life in this case is defined as the amount of time solder paste can sit open on the stencil and maintain printability. This method uses the F1 test board and a solder paste inspection system to measure solder paste volume. This method combines stencil life with response to pause.

This method is a variation on the printed solder paste volume method. Solder paste is applied to the printer in an amount sufficient to run 10 circuit boards. The solder paste is not mixed or added to during this test. Two F1 test boards are printed and volumes measured in the 0.4 mm BGA patterns. The paste sits idle on the printer for 1 hour, and then two more test boards are run and volumes measured. This process is repeated after a cumulative stencil life of 2 hours, 4 hours, and 8 hours on the printer. Solder paste volume average and standard deviation are calculated at each stencil life time. Example results are shown below (Table 4).

Table 4 – Example Results for Stencil Life / Response to Pause

Stencil Life Time	Solder Paste A 0.4 mm BGA Volume Avg. (mil³)	Solder Paste A 0.4 mm BGA Vol. Std. Deviation (mil³)	Solder Paste B 0.4 mm BGA Volume Avg. (mil³)	Solder Paste B 0.4 mm BGA Vol. Std. Deviation (mil³)
0 hours (initial)	450	25	420	40
1 hour	441	28	404	43
2 hours	454	26	382	38
4 hours	439	28	355	42
8 hours	425	25	308	45

Ideal solder paste performance is demonstrated by consistent average and standard deviation of volume over time. Solder paste A showed a slight drop in volume over 8 hours, and the standard deviation was fairly stable. Solder paste B showed a drop in volume over 2 and 4 hours, followed by a large drop between 4 and 8 hours on the stencil. The standard deviation also went up slightly during the course of 8 hours. This might be caused by solvent evaporation out of solder paste B over time, causing a thickening effect. Solder paste A performed better than solder paste B in this method.

This method can be varied based on typical practice in the process. For example, if solder paste is left on the stencil for a maximum of 4 hours before additions are made, then the test can be ended after 4 hours. If the maximum pause time is 1 hour over a lunch break, then the gaps between board runs could be limited to 1 hour. For example, circuit boards could be

run at times 0, 1 hour, 2 hours, 3 hours, and 4 hours. This method gives useful information about the ability of solder paste to function in the normal process. If a more extreme test is desired, then solder paste could sit open on the stencil overnight and volume measured the next day. This would essentially test an 18 or 24 hour stencil life.

The estimated time to run this method depends largely upon the standard practice used in the print process. This method can take as long as 8 hours, which is usually adequate to differentiate between solder pastes. The actual time required for operator interaction is approximately 60 minutes broken up throughout the total test duration.

Stencil life / Reflow performance – F2A test board

This method measures change in reflow performance over the course of the stencil life. The F2A test board is used instead of the F1 test board.

This method is very similar to the stencil life / response to pause test. Solder paste is left on the printer for 8 hours. Two F2A test boards are printed and reflowed at user defined intervals. Typical intervals would be 0 hours, 1 hour, 2 hours, 4 hours, and 8 hours. Wetting, solder balling, graping, and (optionally) voiding are compared at each time interval. Look for changes in performance over time. For example, an increase in solder balling (decrease in overprint percentage) might indicate that a reaction is occurring in the solder paste, causing a loss of activity. It might also indicate that air oxidation of the solder powder is occurring which leads to increased solder balling and possibly graping. A loss of performance indicates instability in the solder paste. It is desirable to use a solder paste that shows stable performance over time.

The estimated time to run this method depends largely upon the standard practice used in the print process. This method can take as long as 8 hours, which is usually adequate to differentiate between solder pastes. The actual time required for operator interaction is approximately 150 minutes broken up throughout the total test duration.

Open time / Mass change

This open time method is quite simple. The mass and appearance of solder paste is monitored over time as the solder paste sits open to the air. A digital scale with resolution to 0.01 grams is used for this test. Two competing processes occur when solder paste is open to the air. Solvents evaporate into the air causing a mass loss, and moisture is absorbed into the solder paste causing a mass increase. Environmental conditions have a dramatic effect on the results of this test. It is best to run this near the printer in the environment in which the solder paste is used. A large mass increase indicates moisture absorption is occurring more quickly than solvent evaporation. Solder paste contaminated with moisture tends to show problems with reflow performance, specifically solder balling and voiding. Solder pastes which lose significant solvent tend to increase in viscosity and tack, which might lead to print issues.

This method consists of placing a measured mass of solder paste in a thin layer on a glass dish. Any inert container can be used, such as a plastic sheet, a beaker, etc. It is not recommended to use a container that might react with the solder paste like certain metals. Typically, 30 - 50 grams of solder paste in a layer approximately 5-10 mm thick is adequate for this test. The solder paste is placed in an area near the printer and allowed to sit open to the air over time. After 8 hours and 24 hours the solder paste is weighed and the mass change calculated (Table 5). The appearance of the solder paste is also evaluated for change (Table 6).

Table 5 – Example Results for Open Time / Mass Change

Open Time	Solder Paste C Mass (grams)	Solder Paste C Change in Mass	Solder Paste D Mass (grams)	Solder Paste D Change in Mass
0 hours (initial)	41.85	NA	42.28	NA
8 hours	41.91	0.06g (0.14%) increase	42.29	0.01g (0.02%) increase
24 hours	42.00	0.15g (0.36%) increase	42.31	0.03g (0.07%) increase

The ideal solder paste does not change mass over time as it sits open to the air. Solder paste C showed a significant increase in mass of 0.15 grams (0.36% wt) over 24 hours, while solder paste D showed a much lower increase in mass of 0.03 grams (0.07% wt). Solder paste D performed better than solder paste C in this test.

Table 6 – Solder Paste Appearance with Open Time

Open Time	Solder Paste C	Solder Paste D
-----------	----------------	----------------

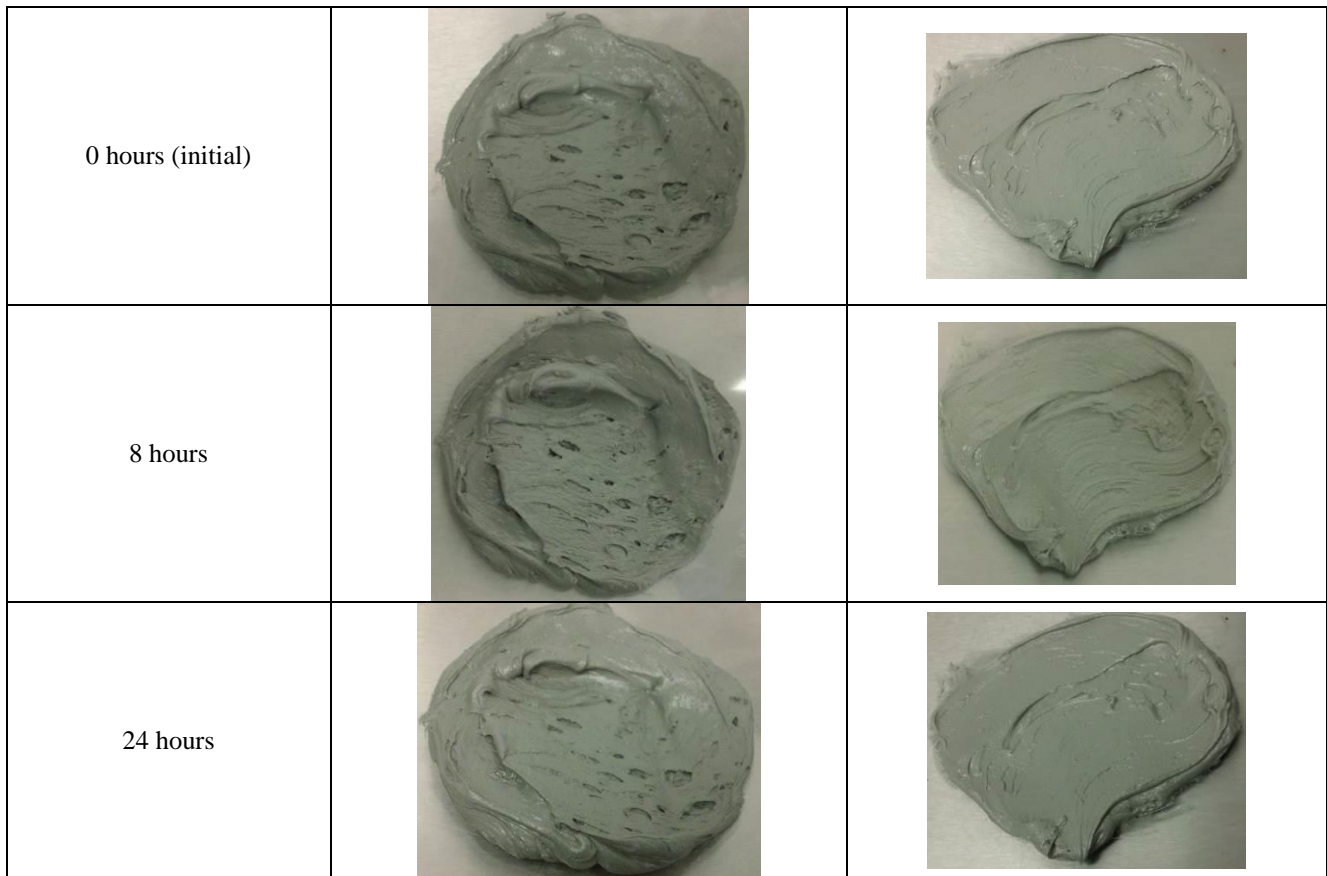

The appearance of the solder paste gives an indication of what is occurring to the paste on the stencil and in the apertures during open times. If the solder paste appears more dry than it did initially, that might indicate potential print issues. If the solder paste appears more wet than it did initially, that might indicate potential reflow issues. In the example above, solder paste C became more wet looking and increased in mass significantly. Solder paste D increased in mass slightly and took on a dry look.

The estimated time for this method is 24 hours. The actual time required for operator interaction is approximately 15 minutes broken up throughout the total test duration.

Tack force over time

This method involves the use of a tack force tester. There are several types commercially available. The tack force tester must be able to test the tack force of the solder paste using the IPC¹² or JIS¹³ standard methods. The idea behind this test is quite simple: monitor changes to tack force over time as the printed solder paste is held open to the air.

Print solder paste onto 6 test slides for each solder paste under evaluation. The slides are then stored near the solder paste printer open to the air and in a location where they will not be disturbed. The tack force is measured initially (time 0), and then again after open times of 1, 2, 4, 8, and 24 hours, looking for changes in tack force. Example results using the JIS tack method are shown below (Table 7)

Table 7 – Example Results for Open Time / Tack Force – JIS Method

Open Time	Solder Paste A Tack (gram force)	Solder Paste B Tack (gram force)	Solder Paste C Tack (gram force)
0 hours (initial)	112	95	105
1 hour	110	98	107
2 hours	115	90	104
4 hours	107	78	108
8 hours	110	55	111
24 hours	100	24	129

Solder paste A was stable over an 8 hour open time but showed a small drop in tack force over 24 hours. This indicates that solder paste A can be printed and held for up to 8 hours prior to reflow. There would be little danger of component shifting or loss of adhesion. Solder paste B was stable for 2 hours but showed a significant drop in tack force at 4 hours, and again at 8 and 24 hours. When using solder paste B, the best practice would be to print, place components, and reflow within 2 hours. Solder paste B should not be used with extended hold times. Solder paste C showed good stability over 8 hours but displayed a significant increase in tack force after 24 hours. If solder paste C were to be reused for multiple days in a row, the printability may suffer due to this increase in tack force.

The estimated time for this method is approximately 15 minutes to print the slides and then 15 minutes per slide to test the tack force. These times apply to each solder paste evaluated. The total time to run this test is 24 hours, but operator interaction is limited to 1 hour and 45 minutes broken up throughout the 24 hour period.

Alternate method for Tack force over time

If the user does not have access to a tack tester, then this alternate method for tack force can be used to gather some information. This alternate method involves printing paste, placing components, and storing the boards on their edge. Watch for components shifting or falling off over time. The advantage of this alternate method is that it can be performed on normal production circuit boards, and it does not require a tack tester. The disadvantages of this method are that gravity influences the results, and tack force of the solder paste is not measured directly.

The same open times can be used as discussed in the normal tack force method: 0, 1, 2, 4, 8, and 24 hours. It is best to print paste and place components on at least 2 circuit boards for each solder paste evaluated. It is recommended that only smaller components are used (0402 or 0201). Larger components tend to fall off very quickly in this test and do not provide good information about the solder paste over time. The circuit boards are mounted in a rack, so that they are held at approximately 90 degrees from the horizontal. At each open time, make observations about component shifting and components that have fallen off the board. The number of components placed initially can be counted, and then the components that remain on the boards counted again at each open time. Ideally, the components are held in place so that no parts shift or fall off during the 24 hour hold time. Example results for this alternate method are shown below (Table 8).

Table 8 – Example Results for the Alternate Open Time / Tack Force

Open Time	Solder Paste A # Components on Board	Solder Paste B # Components on Board
0 hours (initial)	50	50
1 hour	50	48
2 hours	48	46
4 hours	45	40
8 hours	44	29
24 hours	40	18

In this example, 50 components were placed with each type of solder paste. Components fell off of the circuit board with solder paste A slowly over an 8 hour period. After 24 hours, solder paste A lost 10 components or 20% of the initial placement. Solder paste B lost components more quickly over 8 hours, and after 24 hours a total of 32 components were missing. Solder paste B had a total loss of 64% of the initial component placement. Solder paste A performed better in this test than solder paste B.

The time required for each solder paste is approximately 10 minutes to print and place components on 2 circuit boards and then about 2 minutes to make observations after each open time. The total time per solder paste is about 20 minutes broken up over a 24 hour period.

Heat aging of solder paste

Solder paste can be stressed through a few types of accelerated aging methods. These stress tests give some information about the shelf life of the solder paste and also how the solder paste will respond to long or repeated usage on the printer. These stress tests also reveal some information about the potential for reactivity in the solder paste. Highly reactive solder pastes tend to thicken and lose soldering activity over time. The user should be aware that this method might damage the solder paste beyond usability, so it should be run only after all other evaluations are complete.

Heat aging of solder paste is one way to stress solder paste. This method is quite simple. Store sealed jars of solder paste in an oven set to 40 to 45 deg C (104 to 113 deg F) over a 3 day time period. Alternately, a water or sand bath could be used but the paste should be sealed inside of a plastic bag to prevent possible water contamination. After heat aging, solder paste

performance is evaluated using any or all of the methods described previously. Recommended methods after heat aging are volume measurement, reflow performance, and tack force. The data for the fresh solder paste should be compared to the heat aged solder paste. Ideally, a solder paste shows no change in performance before and after heat aging. Solder pastes which show a drop in performance should be scored lower in this method.

More aggressive versions of this method can be performed. Hold times can be increased to 4 to 7 days. The storage temperature can also be increased up to a maximum of 50 deg C (122 deg F). It is not recommended to store solder pastes above 50 deg C in this test, because adverse reactions may occur which will obscure the results. After heat aging, other performance methods are run and the performance compared to that of the fresh solder paste.

This method can be used to simulate the worst possible storage conditions of the solder paste. For example, a solder paste shipment is received during the summer time. The solder paste is misplaced in a shipping/receiving area without temperature control. The solder paste may be exposed to 45 deg C temperatures for longer than 3 days.

The amount of time required for this test is highly dependent upon the methods chosen to evaluate performance. The heat aging itself requires less than 10 minutes to set up the oven or water bath and store the pastes for the duration of the stress test.



Continuous mixing of solder paste

This type of stress test evaluates the ability of the solder paste to withstand continuous and repeated use on the printer. It also measures the reactivity of the paste with air. This method gives another measure of the stability of solder paste. Ideal solder pastes are stable over time and their properties should remain consistent throughout the life of the solder paste. The user should be aware that this method might damage the solder paste beyond usability, so it should be run only after all other evaluations are complete.

This test involves continuously printing solder paste over an 8 hour period with no breaks. A printer will have to be taken out of production in order to run this test. A full container of solder paste is loaded onto the printer and is not replenished during the course of this method. A sufficient amount of solder paste for this test is 250 to 500 grams. The solder paste is printed continuously for 8 hours with a board held against the stencil so that the paste does not flow through the apertures. Solder paste may flow outside of the blades, and may have to be moved back to the center of the blades periodically. After the 8 hour print test, then solder paste performance is evaluated primarily through volume measurement and reflow performance. Any or all of the methods previously detailed can be used to evaluate performance. As with other stress tests, data for the fresh solder paste should be compared to the stressed solder paste.

Alternately, a kitchen type mixer can be used to stress the solder paste with 8 hours of continuous mixing. Kitchen mixers are relatively inexpensive and are readily available. The advantages of using a kitchen type mixer are that a printer is not taken out of production, and the paste stays in the bowl without the need to manually move it back under the blades. Pictures of the solder pastes initially, after 8 hours of mixing, and after the mixed paste sat undisturbed overnight are shown below (Table 9).

Table 9 – Solder Paste Appearance after Continuous Mixing

Mix Time	Solder Paste E	Solder Paste F
0 hours (initial)		



Both solder pastes took on a wet and creamy look after 8 hours of continuous mixing. This is due to shear thinning of the solder paste. As the solder paste sat undisturbed, the viscosity recovered to a steady state. After the mixed pastes sat undisturbed overnight, they became dry and dull looking and were very thick. Solder paste F was drier and thicker than solder paste E. Solder paste F performed worse than solder paste E in this test. This indicates that Solder paste F is less stable and more reactive to air exposure and mixing.

Stable pastes normally show a slight decrease in viscosity, but no change in print or reflow performance. Stable pastes also show very little change in appearance. Unstable pastes show an increase in viscosity and an appearance change. A dramatic thickening of the solder paste indicates a reaction with air through the energy provided by continuous mixing. An appearance change to a dry, dull, or chunky look also indicates a reaction took place. Solder pastes that react in this test may give inconsistent results in long term printing and may also have issues with solder balling or graping.

The amount of time required for this test is highly dependent upon the methods chosen to evaluate performance. The continuous mixing method itself requires approximately 15 minutes to set up and clean up after it is finished.

Water solubility of raw solder paste

This method is intended for use with water soluble solder pastes. Most water soluble solder paste are actually water washable, and do not truly dissolve in water. Surfactants included in the solder paste are intended to help saponify and wash away the non-water soluble ingredients in the flux. Water solubility of the raw solder paste is easy to determine and gives some general information about the washability of the solder paste flux.

The raw solder paste can easily be tested by placing a small spatula of paste (approximately 10-15 grams) into a transparent glass or beaker full of water (200 - 300 mL). Alternately, the solder paste flux could be used in place of the solder paste. Stir the solder paste into the water until the mixture is uniform, and then allow the glass to sit undisturbed. Once the solder powder settles to the bottom, look through the water. If the water is cloudy, or if there are floating solids on the surface of the water, then the solder paste is not truly water soluble. When two solder pastes are compared, the amount of paste used in each test should be the same. The difference in cloudiness of the water is compared (Figure 8).



Figure 8 - Solder paste mixed with water. Water washable (left) vs. water soluble (right)

The solder paste on the left turned the water cloudy, which indicates that some of the ingredients are not soluble in water. The solder paste on the right dissolved, leaving the water clear. The solder powder settled to the bottom in both cases, and is not expected to dissolve. The solder paste on the right will be easier to clean in a water wash system.

The amount of time required for the raw solder paste water solubility test is approximately 15 minutes per solder paste tested.

Water solubility of reflowed flux residue

This method is intended for use with water soluble solder pastes. Water solubility of the flux after reflow can be determined through a soak test in a container of water.

This method is quite simple. Print 3 circuit boards for each solder paste. Components should be placed if possible. The first board is reflowed only 1 time. The second board is reflowed 2 times. The third board is reflowed 3 times. Multiple reflow cycles thermally stress the flux residue making it more difficult to wash off. Soak each circuit board in a container full of water, without agitation for the duration of the test. Inspect the boards for flux removal every 5 minutes up to a total time of 30 minutes. This test can be ended once the flux residue is removed. Some solder paste fluxes can easily be removed after 5 minutes of soaking while others cannot (Figure 9).



Figure 9 - Reflowed solder paste before (top) and after (bottom) soaking in water for 5 min. The number of reflow cycles increases from left to right (1, 2, and 3)

In this example, the reflowed flux grew darker in color with each successive reflow. After soaking for 5 minutes, the flux residue was completely removed from the circuit board reflowed 1 time. The circuit board reflowed 2 times had slight flux residue left. There is a considerable amount of flux residue left on the circuit board reflowed 3 times. In this test, an additional 25 minutes of soaking was required for a total of 30 minutes soak time, before all of the flux was removed from the circuit board reflowed 3 times. For comparison, another water soluble paste was completely removed from all three boards after 5 minutes of soaking.

Alternately, the circuit boards can be placed into the water wash system and cleaned using the normal process. Components should be placed in this version of the method in order to evaluate washability in tight clearances. Inspect the circuit boards for complete removal of flux and make observations about the differences in cleanability after 1, 2, and 3 reflow cycles.

A more challenging version of this method is to reflow circuit boards 1, 2, and 3 times and then hold them for 72 hours. Perform wash tests after the 72 hour hold time. This simulates multiple reflows in addition to staging circuit boards over a weekend prior to washing. This test can be modified to challenge the solder pastes using the worst possible case for cleanability.

Ionic contamination (ROSE) testing can be done to determine the amount ionic residue left on the circuit boards after this test. In this variation, the boards should be washed for a fixed period of time, e.g. 5 minutes. Alternately, the circuit boards could be run through the normal wash equipment. Ionic contamination testing is run after drying the circuit boards. This gives a quantitative measurement that can be used to compare and contrast the washability of water soluble solder pastes.

If knowing the chemical nature of the ionic contamination is desired, then ion chromatography (IC) can be used. Again, the circuit boards should be washed for a fixed period of time or run through the normal wash equipment. After drying, the ionic species are extracted from the circuit boards and run through an ion chromatograph. This gives quantitative data about select ions left behind by the flux residue. Ion chromatography is commonly used to measure halide ions through an IPC standard method.

The amount of time required for the reflow and wash test is about 45 min per solder paste. If ionic contamination or ion chromatography are run, then the time required will increase.

DISCUSSION

Time requirements

The properties of most importance to the user will determine which methods to use and subsequently the amount of time required. It is the intent of this paper to present methods that are quick to run and generate useful data. A summary of the methods and time required is in the table below (Table 10).

Table 10 – Method Summary and Time Required

Method	Property Evaluated	Time Required per Solder Paste
Solder paste volume average & standard deviation SPI measurement	Printability of solder paste through small area ratio apertures	60 minutes
*Alternate volume average & standard deviation Mass measurement	Printability of solder paste overall	30 minutes
Bridging at print	Bridging potential for solder paste, and brick definition	10 minutes Concurrent with volume
Reflow performance on ENIG	Wetting, solder balling, graping, and voiding	30 minutes
*Alternate reflow performance on OSP Run in addition to ENIG	Wetting, solder balling, graping, and voiding on OSP	20 minutes
Stencil life / Response to pause	Change in printability of a solder paste over time, as it sits on the stencil	60 minutes Spread out over 8 hours
Stencil life / Reflow performance	Change in reflow performance as the solder paste sits on the stencil	150 minutes Spread out over 8 hours
Open time / Mass change	Environmental effect on solder paste	15 minutes Spread out over 24 hours
Tack force over time Tack tester	Ability of solder paste to retain tack force when open to air	1 hour 45 minutes Spread out over 24 hours

*Alternate tack force over time Component movement	Ability of solder paste to hold components in place at 90° angle	20 minutes Spread out over 24 hours
Heat aging	Gives information about shelf life and potential reactivity of solder paste	10 minutes plus methods used after aging
Continuous mixing	Ability of solder paste to tolerate repeated printing, and potential reactivity with air	15 minutes plus methods used after mixing
Water solubility of raw solder paste	Water solubility of raw paste	15 minutes
Water solubility of reflowed flux residue	Water washability of flux after reflow	45 minutes plus Ionic contamination methods

The total amount of time required to evaluate a solder paste depends upon the methods chosen. For example, if the methods used include volume average and standard deviation using SPI and Reflow performance on ENIG, then the time required for one solder paste is 90 minutes. It is always recommended to run a control solder paste for comparison, therefore in this example the total time to evaluate two solder pastes is 180 minutes.

Scoring system

A system for scoring the performance of solder pastes is presented here. This scoring system can be modified to fit the needs of the user. First the importance of the properties of the solder paste must be ranked. Rank these properties using a simple (1, 2, 3) system. Assign a rank of 3 to the most important properties, assign a rank of 2 to moderately important properties, and finally assign a rank of 1 to the least important properties. If the property will not be tested, then assign NA or remove it from the list. An example of importance ranking is shown below (Table 11).

Table 11 – Example Ranking of Importance of Solder Paste Properties

Method	Rank of Importance (3=highest, 2=moderate, 1=lowest)
Solder paste volume average & standard deviation SPI measurement	3
*Alternate volume average & standard deviation Mass measurement	NA
Bridging at print	3
Reflow performance on ENIG	3
*Alternate reflow performance on OSP Run in addition to ENIG	NA
Stencil life / Response to pause	1
Stencil life / Reflow performance	1
Open time / Mass change	2
Tack force over time Tack tester	NA
*Alternate tack force over time Component movement	NA
Heat aging	NA
Continuous mixing	2
Water solubility of raw solder paste	NA
Water solubility of reflowed flux residue	NA

In this example, methods ordered by importance are listed below.

Highest Rank 3: Solder paste volume by SPI, Bridging at print, Reflow performance on ENIG

Moderate Rank 2: Open time/mass change, Continuous mixing

Lowest Rank 1: Stencil life/response to pause, Stencil life/reflow performance

NA: Methods will not be run

Assign a score for each solder paste run within each method. Use a scoring range of 1 to 3. A score of 3 represents best performance for that solder paste in that method. A score of 2 represents moderate performance. A score of 1 represents the worst performance. These scores must be assigned by comparing and contrasting performance of each solder paste tested. Next, calculate the performance of each solder paste for each method by multiplication of the importance rank by the score.

Finally, add up the performance metrics for each solder paste and compare the results. An example of solder paste scoring and performance is shown below (Table 12).

Table 12 – Example of Scoring and Performance for Solder Pastes

Method	Importance Rank	Score Solder Paste G	Score Solder Paste H	Performance (Rank x Score) Solder Paste G	Performance (Rank x Score) Solder Paste H
Solder paste volume average & standard deviation (SPI measurement)	3	3	1	9	3
Bridging at print	3	1	2	3	6
Reflow performance on ENIG	3	3	1	9	3
Open time / Mass change	2	3	2	6	4
Continuous mixing	2	3	1	6	2
Stencil life / Response to pause	1	2	3	2	3
Stencil life / Reflow performance	1	1	2	1	2
TOTAL PERFORMANCE METRIC				36	23

In this example, solder paste G performed better overall than solder paste H. Solder paste H had better scores in a few of the methods including bridging, stencil life/response to pause, and stencil life/reflow performance. Two of these methods were ranked of least importance which reduced the performance metric for solder paste H, giving solder paste G an overall higher performance.

CONCLUSIONS

It is possible to dispel the “black magic” of solder paste through the use of challenging test methods. The methods presented in this paper allow the user to differentiate between solder pastes. The methods are quick to run and give quantitative data about solder paste performance. Performance metrics can be calculated to give an overall rating for each solder paste. This enables the user to choose the best solder paste for her or his process based on quantitative data rather than gut feel.

ACKNOWLEDGEMENTS

The author would like to thank Jabil Circuit, who generously allowed us to use their test board designs. Many thanks also go to the staff of FCT Assembly, who aided in developing these methods and performed the testing.

REFERENCES

- [1] R. Lasky, D. Santos, A. Bhawe, “Leaded and Lead-Free Solder Paste Evaluation Screening Procedure”, Proceedings of SMTA International, 2003.
- [2] T. Jensen, “Solder Paste Evaluation Techniques to Simplify the Transition to Pb-Free”, Indium Corp, 2006.
- [3] J. Nguyen, D. Geiger, D. Shanguan, “Evaluation of Lead Free Solder Paste Materials for PCBA”, Proceedings of IPC Apex Expo, 2011.
- [4] J. Nguyen, R. Aranda, D. Geiger, M. Kurwa, “Assembly Process Feasibility of Low/No Silver Alloy Solder Paste Materials”, Proceedings of IPC Apex Expo, 2013.
- [5] E. Guene, S. Teh, “Reliability Assessment of No-Clean and Water-Soluble Solder Pastes Part I”, Proceedings of IPC Apex Expo, 2013.
- [6] F. Xie, D. Baldwin, P. Houston, B. Lewis, H. Wu, “Next Generation No-Clean Lead Free Solder Paste Evaluation for Fine Pitch Application”, Proceedings of SMTA International, 2013.
- [7] K. Seelig, T. O’Neill, K. Pigeon, M. Maaleckian, A. Monson, W. Machado, C. Shea, “Product Testing of Ni-Modified SnCu Solder Paste”, Proceedings of SMTA International, 2013.
- [8] S. Anson, M. McLaughlin, A. Argueta, “Evaluation of Solder Pastes for High Reliability Applications”, Proceedings of SMTA International, 2013.
- [9] S. Stengel, M. Reichenberger, G. Ohm, J. Trodler, A. Heilmann, “Characterization of Solder Paste Wetting/Spreading Performance – Current Status in International Norms and Standards”, Proceedings of SMTA International, 2013.
- [10] E. Guene, S. Teh, “Reliability Assessment of No-Clean and Water-Soluble Solder Pastes Part II”, Proceedings of IPC Apex Expo, 2014.
- [11] L. Bruno, T. Johnson, “Printing of Solder Paste – A Quality Assurance Methodology”, Proceedings of IPC Apex Expo, 2014.
- [12] Solder Paste Task Group (5-24b), “Requirements for Soldering Pastes”, IPC J-STD-005A, February 2012.
- [13] Japanese Industrial Standard, “Solder paste”, JIS Z 3284, 1994.



Click or call us today and set-up
an evaluation with one of our
Field Application Engineers

970-346-8002



Contact us today and request
samples of our SMT solders, stencils
and coatings

support@fctassembly.com



Visit our website today and
download *FREE* technical papers
and presentations

www.fctassembly.com